

## RUBBER SLEEVE KNIFE GATE VALVE

The **SERIES 60** knife gate is a water valve designed for a wide range of industrial applications. The double-seated design provides bi-directional shut off. The design of the valve body and the rubber sleeves makes the **SERIES 60** valve suited for use on handling abrasive slurries in industries such as:

- Mining
- Chemical Plants
- etc.
- Power Plants
- Waste Water Treatment

**Sizes:** 2" to 24" (larger diameters on request)

<b>Working Pressure:</b>	Sizes 2" to 5" :	128 PSI
	Sizes 6" :	85 PSI
	Sizes 8" to 10" :	70 PSI
	Sizes 12" :	60 PSI
	Sizes 14" to 16" :	42 PSI
	Sizes 18" to 24" :	35 PSI

**Note:** Availability for gate manufacturing in other materials to achieve higher working pressures. Please consult our technical department.

**Standard Flange Connection:** ANSI B16.5 (class 150)  
DIN PN 10

**Other :** (On request)

DIN PN 6	DIN PN 16	DIN PN 25
BS "D" and "E"	ANSI 125	

Standard face to face dimensions according to MSS SP-81

All ORBINOX valves are tested prior to shipping

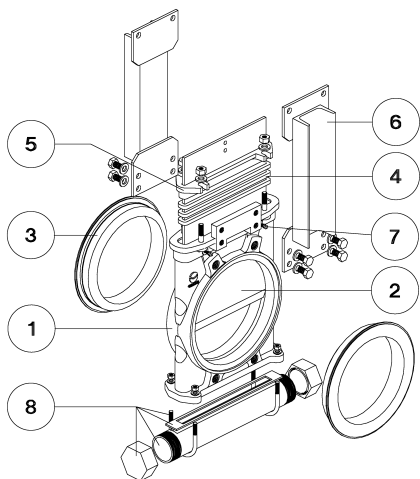

### STANDARD PARTS LIST

Part:	Cast Iron	Stainless Steel:
1- Body	GG25	CF8M
2- Gate	AISI 304	AISI 316
3- Sleeves	Natural Rubber	
4- Packing	AH	NT
5- Gland Follower	S.G. Iron/ Carbon Steel	AISI 316
6- Support Plate	Carbon Steel – Epoxy coated	
7- Grease Nipple	Acc. To DIN 3402	
8- Splash Guard	See options	

ORBINOX reserves the right to change specifications without notice. OBX 1/01 4TH EDITION



**ORBINOX SPAIN**, Polig. Ind. Anoeta – Apdo 80 – 20400 Tolosa, Spain Tel: 943-69 80 30 Fax: 943-65 30 66 e-mail: [orbinox@orbinox.com](mailto:orbinox@orbinox.com)



**ORBINOX CANADA**, 2050 Dagenais West, Laval, Quebec, H7L 5W2 Tel: 450-622-8775 Fax: 450-622-6831 e-mail: [orbe@orbevalve.com](mailto:orbe@orbevalve.com) / [www.orbevalve.com](http://www.orbevalve.com)



**ORBINOX USA**, 311 North Front Street, Amory, Mississippi 38821 Tel: 662-256-2227 Fax: 662-256-2119 e-mail: [orbe@orbevalve.com](mailto:orbe@orbevalve.com) / [www.orbevalve.com](http://www.orbevalve.com)

**DESIGN FEATURES**

**BODY:**

- Wafer style cast **monoblock**, designed with reinforcing ribs in larger diameters providing the body with extra strength.
- Internal body design allows the gate to be fully guided.
- The grease nipples allow the gate to be lubricated, thus enhancing its capacity to slide between the sleeves.
- Its design allows for drainage from the lower part, where a cover or a bottom splash guard can be installed.

**GATE:**

- The stainless steel gate is polished on both sides.
- Machined bottom gate to an edge for easier seat separation when closing the valve and longer wearing life of the rubber sleeves.

**SEAT/ RUBBER SLEEVES**

- The seat is made of two highly resistant, long-lasting sleeves, made of elastomer with a stainless steel core.
- The two sleeves are in permanent contact with each other when the valve is in the open position. There are no seat cavities to wear or that could produce build-up with solids.
- While the valve is either in the open or closed position, the media doesn't come into contact with the internals of the body.
- This design allows easy sleeve replacement and avoids gasket installation between the flange and the valve.

**PACKING CHAMBER:**

- Braided long life packing with EPDM o-ring for a tighter packing chamber seal.
- Smooth chamber and cast gland follower with equally distributed gland bolts provides uniform compression of packing.

**STEM:**

- Corrosion resistance stainless steel stem.
- Single pitch Acme thread reduces torque on handwheel operator and eliminates installation of a gear operator on larger diameters.
- Standard stem protector on all handwheel actuators gives additional protection against dust while the valve is in the open position.

**ACTUATORS:**

- All Orbinox actuator models are supplied with a standard mounting kit to allow easy installation on site.

**YOKE & SUPPORT PLATES:**

- EPOXY coated steel (stainless steel available on request).
- Compact design makes it extremely robust even in the most severe conditions.

**EPOXY COATING:**

- The electrostatic applied epoxy coating on all ORBINOX cast iron and carbon steel valve bodies and components make the valves corrosion resistant.

**GATE SAFETY PROTECTION:**

- Gate guards are available upon request for areas where safety is a concern.
- The design feature prevents any objects from getting caught accidentally while the gate is moving.

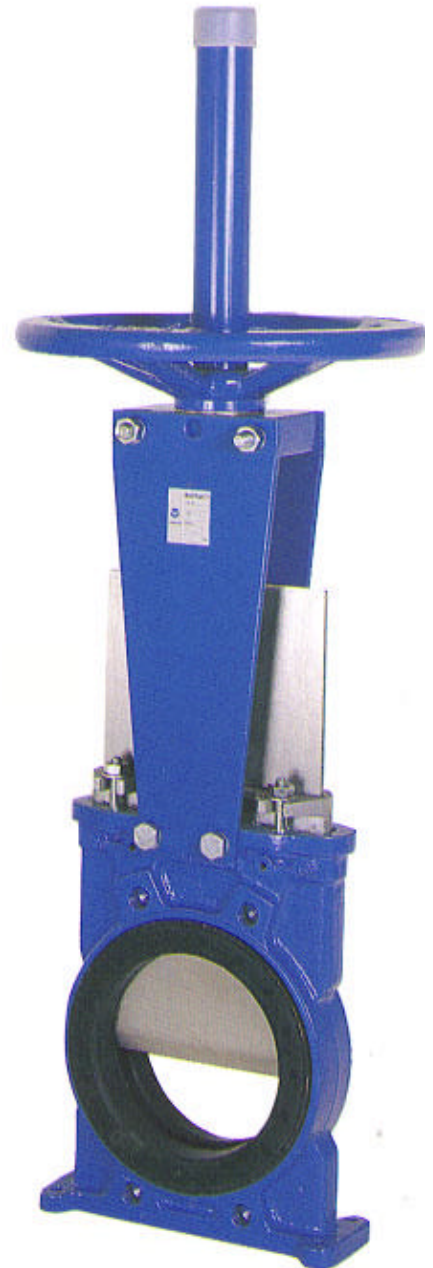

**OTHER OPTIONS**

**BOTTOM SPLASH GUARD**

- Developed to prevent any media from leaking to the atmosphere while valve cycles.
- Media is easily flushed while valve is in operation.

**OTHER MATERIALS OF CONSTRUCTION AVAILABLE:**

- Special alloys such as AISI 317, 254SMO, Hastelloys, Titanium, etc.

**FABRICATED VALVES:**

- Orbinox is equipped for in house fabrication of special valves.
- Design is based on application, diameter, pressure, material of construction, etc.

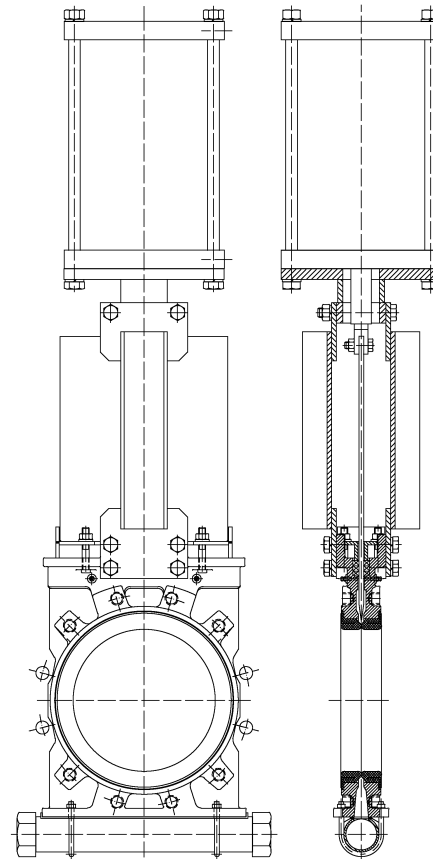

**TYPES OF SUPPORT PLATES**

There are different types of support plates depending on the size of the valve.

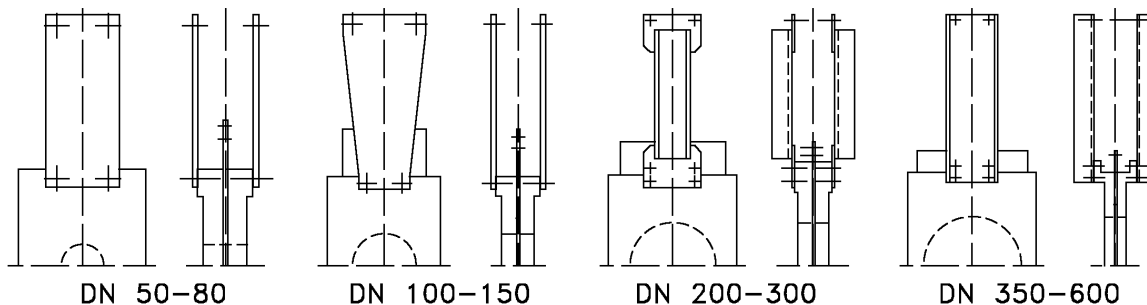

DN 50-80

DN 100-150

DN 200-300

DN 350-600

**TIPO DE PLACA SOPORTE SEGUN TAMAÑO**



## ACTUATOR OPTIONS

- Handwheel (rising or non-rising stem)
- Chainwheel
- Lever
- Bevel Gear
- Others (square nut...)
- Electric
- Double Acting Pneumatic
- Single Acting Pneumatic
- Hydraulic

All actuators supplied by ORBINOX are interchangeable.

### FAIL SAFE SYSTEMS

Used on pneumatic actuated valves.

#### SINGLE ACTING / SPRING RETURN

Available in sizes 2" to 8", larger on request.

Supply Pressure: Minimum 75 PSI  
Maximum 100 PSI

Options: Fail open  
Fail close

#### SINGLE ACTING / VOLUME TANK

Available in all sizes.

Supply Pressure: Minimum 50 PSI  
Maximum 100 PSI

Options: Pneumatic Fail safe  
Electropneumatic Fail safe

### ACCESSORIES

- Mechanical Stops
- Locking Device
- Actuator Manual Override
- Solenoid Valves
- Positioners
- Limit Switches
- Electric Controls
- Floor Stands
- Stems Extensions

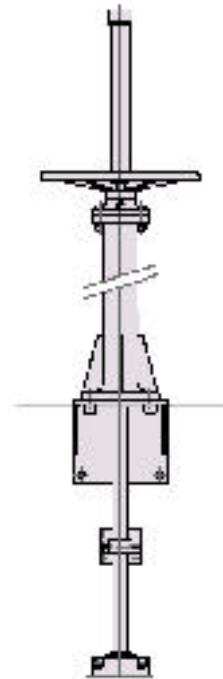

Wide range of valve extensions available.

For further information about fail safe systems and valve extensions, please refer to SERIES 10 section

For additional information, please consult the factory.



SEAT / SEALS			PACKING		
Material	Max.Temp.(°C)	Applications	Material	Max.Temp.(°C)	pH
Natural Rubber	75	General	Tallowed cotton (AH)		6 – 8
EPDM	120	Acids and non mineral oils	Dry cotton (AS)		6 – 8
Neoprene	90	Oils and solvents	PTFE impregn. Natural fibre (NT)		4 – 12
Chlorobutyl	125	High temperatures	PTFE impregn. Synth fibre (ST)		2 – 13
			Braided PTFE (TH)		0 - 14

All of them are reinforced with a stainless steel core.

NOTE: Above includes an elastomer O-ring, except TH.

## SEAT

Double-seated design, bi-directional. The easily replaceable moulded elastomer sleeves form a tight seal against each other when the valve is open (providing free port and protecting metal parts) and seal against the gate when the valve is closed.

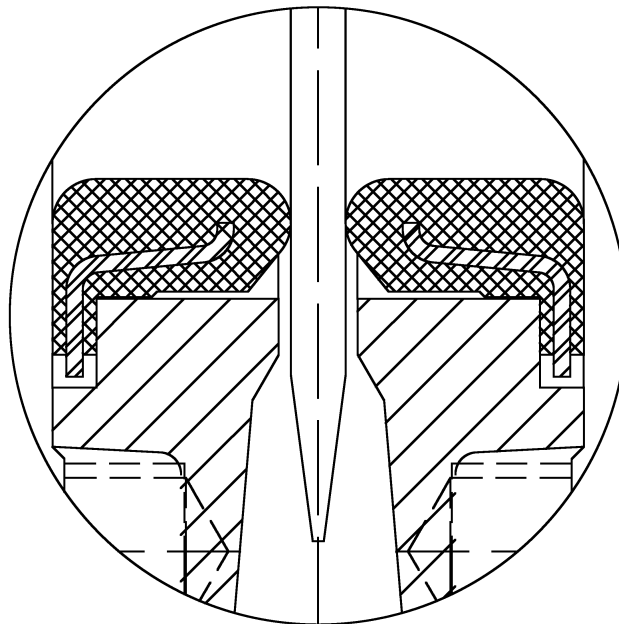

## HANDWHEEL (rising stem)

- Standard handwheel actuator.
- Options:
  - Locking device
  - Extensions
- Valve sizes available in 2" to 24"
- For other options and dimensions, please consult our technical department.

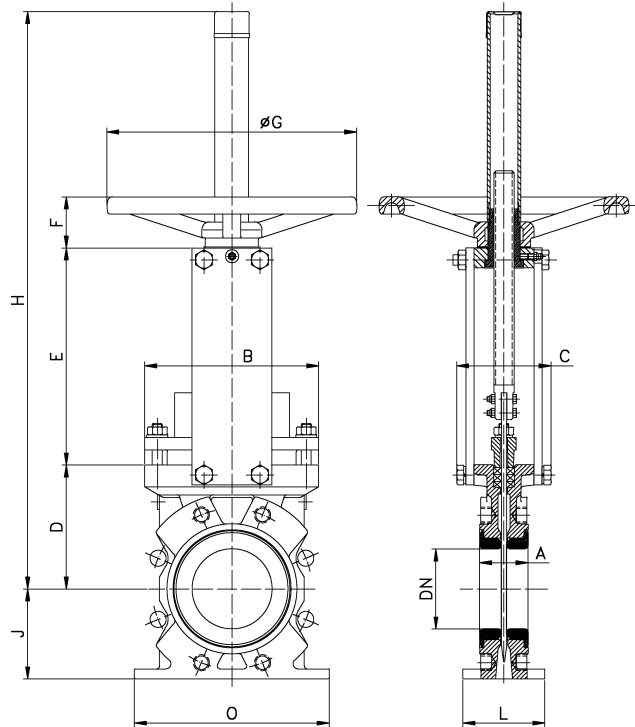

SIZE	A	B	C	D	E	F	G	H	J	L	O	Weight (lbs)
2"	1.9	5.5	3.6	4.1	6.6	2.0	9.8	18.1	2.5	2.7	7.1	22
2.5"	1.9	6.1	3.6	4.5	7.6	2.0	9.8	19.5	2.8	2.7	7.7	27
3"	2.0	6.9	3.7	4.9	8.5	2.0	9.8	22.8	3.5	3.2	7.7	32
4"	2.0	7.0	4.2	5.5	10.0	2.0	11.8	26.4	3.9	3.2	8.9	48
5"	2.2	8.1	4.2	5.9	10.9	2.5	11.8	28.9	4.8	3.2	8.5	53
6"	2.2	9.1	4.2	6.9	12.2	2.5	11.8	31.1	5.1	3.2	9.6	57
8"	2.8	11.4	7.4	8.1	14.3	2.5	16.1	38.2	6.3	3.7	11.4	87
10"	2.8	13.6	7.9	9.6	17.3	2.5	16.1	43.4	7.9	3.7	13.8	139
12"	3.0	15.7	7.9	11.0	19.4	2.7	16.1	50.0	9.1	3.7	15.9	158
14"	3.0	17.6	11.4	12.8	21.6	2.8	21.7	54.0	10.2	4.6	18.1	211
16"	3.5	19.8	11.4	13.8	24.7	3.8	31.5	63.7	11.5	4.6	20.1	414
18"	3.5	21.9	11.4	16.5	26.8	3.8	31.5	70.7	12.5	4.6	22.4	475
20"	4.5	24.3	11.4	18.2	29.7	3.8	31.5	76.8	13.6	5.1	24.8	603
24"	4.5	28.5	11.4	20.1	34.1	3.8	31.5	87.4	15.7	5.1	29.1	700



## PNEUMATIC CYLINDER

• The standard pneumatic actuator (double acting on-off cylinder) consists of:

- Carbon steel construction
- Stainless (AISI 304) Piston Rod
- Nitrile Coated Steel Piston

• Valve sizes available in 2" to 24", larger on request.

• Supply Pressure: minimum 40 PSI - maximum 150 PSI

• **All valves installed in a horizontal position, pneumatic actuators must be supported.**

• NOTE: Depending on the application and service conditions Orbinox can supply larger bore size cylinders. The table below shows the most common used bore sizes. Please consult our technical department for maximum differential pressure and minimum air supply for all pneumatic operated knife gate valves.

• Instrumentation and options on request.

• Instrumentation:

- Positioners
- Flow regulators
- Solenoid valves
- Air preparation units

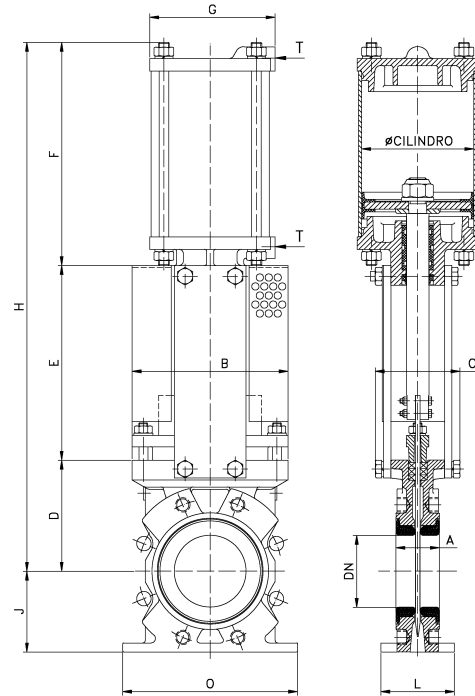

SIZE	A	B	C	D	E	F	G	H	J	L	O	Weight(lbs)	Standard Cyl	Connect
2"	1.9	5.5	3.6	4.1	6.6	8.0	4.5	18.7	2.5	2.7	7.1	22	C100/95	1/4" G
2.5"	1.9	6.1	3.6	4.5	7.6	8.7	4.5	20.9	2.8	2.7	7.7	29	C100/110	1/4" G
3"	2.0	6.9	3.7	4.9	8.5	9.8	5.5	23.2	3.5	3.2	7.7	32	C125/120	1/4" G
4"	2.0	7.0	4.2	5.5	10.0	11.1	6.9	26.7	3.9	3.2	8.9	48	C160/150	1/4" G
5"	2.2	8.1	4.2	5.9	10.9	12.1	6.9	29.0	4.8	3.2	8.5	53	C160/205	1/4" G
6"	2.2	9.1	4.2	6.9	12.2	13.3	6.9	32.4	5.1	3.2	9.6	57	C160/175	1/4" G
8"	2.8	11.4	7.4	8.1	14.3	16.1	8.7	38.4	6.3	3.7	11.4	87	C200/260	3/8" G
10"	2.8	13.6	7.9	9.6	17.3	19.1	10.9	46.0	7.9	3.7	13.8	139	C250/320	3/8" G
12"	3.0	15.7	7.9	11.0	19.4	22.2	15.0	52.6	9.1	3.7	15.9	158	C300/365	1/2" G
14"	3.0	17.6	11.4	12.8	21.6	24.0	15.0	58.3	10.2	4.6	18.1	211	C300/365	1/2" G
16"	3.5	19.8	11.4	13.8	24.7	28.1	17.5	66.7	11.5	4.6	20.1	414	C350/475	3/4" G
18"	3.5	21.9	11.4	16.5	26.8	30.1	17.5	73.5	12.5	4.6	22.4	475	C350/525	3/4" G
20"	4.5	24.3	11.4	18.2	29.7	32.6	20.3	80.6	13.6	5.1	24.8	603	C400/575	3/4" G
24"	4.5	28.5	11.4	20.1	34.1	37.0	20.3	91.1	15.7	5.1	29.1	700	C400/685	3/4" G



## FLANGE AND BOLTING DETAILS

### DIN PN10

DN	K	n°	M	T	
50	125	4	M-16	8	4 - -
65	145	4	M-16	8	4 - -
80	160	8	M-16	8,7	4 - 4
100	180	8	M-16	8,7	4 - 4
125	210	8	M-16	8,7	4 - 4
150	240	8	M-20	10,3	4 - 4
200	295	8	M-20	12	4 - 4
250	350	12	M-20	12	8 - 4
300	400	12	M-20	12	8 - 4
350	460	16	M-20	15	12 - 4
400	515	16	M-24	15	12 - 4
450	565	20	M-24	15	16 - 4
500	620	20	M-24	22,2	16 - 4
600	725	20	M-27	22,2	16 - 4

### ANSI B16.5, class 150

DN	K	n°	M	T	
2"	4 3/4"	4	5/8" UNC	5/16"	4 - -
2 1/2"	5 1/2"	4	5/8" UNC	5/16"	4 - -
3"	6"	4	5/8" UNC	11/32"	4 - -
4"	7 1/2"	8	5/8" UNC	11/32"	4 - 4
5"	8 1/2"	8	3/4" UNC	11/32"	4 - 4
6"	9 1/2"	8	3/4" UNC	15/32"	4 - 4
8"	11 3/4"	8	3/4" UNC	15/32"	4 - 4
10"	14 1/4"	12	7/8" UNC	15/32"	8 - 4
12"	17"	12	7/8" UNC	15/32"	8 - 4
14"	18 3/4"	12	1" UNC	19/32"	8 - 4
16"	21 3/4"	16	1" UNC	19/32"	12 - 4
18"	22 3/4"	16	1 1/8" UNC	19/32"	12 - 4
20"	25"	20	1 1/8" UNC	7/8"	16 - 4
24"	29 1/2"	20	1 1/4" UNC	7/8"	16 - 4

